

**FNCEF200
FNCEF250**



Cleaning Guide:

See instructions with product packaging

Falcon Ceiling Exhaust Fans

- Easy to clean clip on grille
- High performance ball bearing motor
- Compatible with our Hyena Surface Sockets

FNCEF200 - Ceiling Exhaust Fan 200mm

- **Cut out size: Ø 245mm / Overall diameter 300mm**
- 107mm product height without fascia
- 120mm product height including fascia
- 100mm minimum height clearance from rooftop to ceiling
- 214mm air outlet diameter
- Air flow 280m³ per hour
- 25 Watt ball bearing motor



Easy to Clean Grille

FNCEF250 - Ceiling Exhaust Fan 250mm

- **Cut out size: Ø 295mm / Overall diameter 355mm**
- 105mm product height without fascia
- 115mm product height including fascia
- 100mm minimum height clearance from rooftop to ceiling
- 263mm air outlet diameter
- Air flow 401m³ per hour
- 30 Watt ball bearing motor



High Performance Ball Bearing Motor



Frame design has rotating clamp lugs for ease of installation.

Cross Reference Chart

Trader	Clipsal*
FNCEF200	CE200
FNCEF250	CE250

Catalogue Number	Description
FNCEF200	Ceiling Exhaust Fan 200mm
FNCEF250	Ceiling Exhaust Fan 250mm

PLEASE NOTE: Specifications on documentation prior to 30.05.24 may vary slightly, and information within this document shows most recent information, relating to latest FNCEF200 and FNCEF250 models currently in production.

*The Clipsal brand and associated products are registered trademarks of Schneider Electric (Australia) Pty Ltd. GSM Electrical (Australia) Pty Ltd, the TRADER brand and its products, have no endorsement or affiliation with Schneider Electric Pty Ltd.

Certification Number:
GMA-510581-EA

GSM Electrical (Australia) Pty Ltd
Level 2, 142-144 Fullarton Road, Rose Park SA 5067
P: 1300 301 838 F: 1300 301 778 E: service@gsme.com.au
www.gsme.com.au



**FNCFDR
FNCFDS
FNCFDG**



Cleaning Guide:

See instructions with product packaging



Falcon Ceiling Exhaust Fan Ducted

- Ideal for rapid removal of steam and odours
- Easy to clean grille
- Quiet operation
- Built in non-return draft excluder
- Retro-fit for 295mm round cut-out
- Plug and lead fitted
- No duct included (150mm duct compatible)
- Suitable for ceilings between 5mm and 12mm
- 40 Watt Ball Bearing Motor
- Ducting Outlet Ø150mm
- Airflow 350 m³/h
- Cutout size Ø295mm
- **FNCFDS** once the fascia has been attached the fascia can be rotated approx. 45deg clockwise/anti-clockwise to gain the correct alignment.
- **FNCFDG** (Grille) - includes fly mesh and duct clamps (150mm duct compatible)

SAFETY WARNING: All power outlets or electrical wiring must be installed by a licensed and qualified electrician.

Catalogue Number	Description
FNCFDR	Ceiling Exhaust Fan Ducted, Round
FNCFDS	Ceiling Exhaust Fan Ducted, Square
FNCFDG	Ceiling Exhaust Fan Ducted, Grille

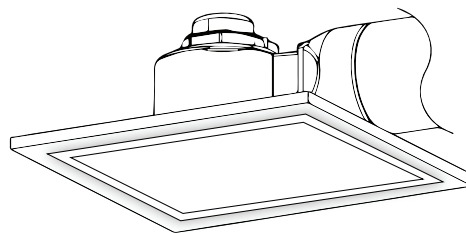
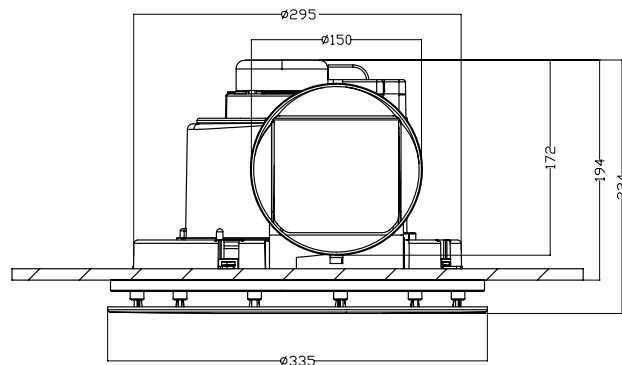

FNCFDS

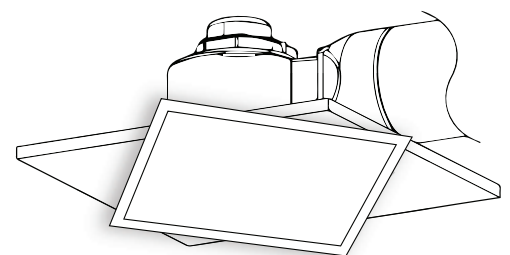

FNCFDS rotated approx 45deg

Certification Number:
GMA-512149-EA

GSM Electrical (Australia) Pty Ltd
Level 2, 142-144 Fullarton Road, Rose Park SA 5067
P: 1300 301 838 F: 1300 301 778 E: service@gsme.com.au
www.gsme.com.au



**FNCEFDSR
FNCEFDSS**



Cleaning Guide:

See instructions with product packaging



Falcon Ceiling Exhaust Fans Ducted Round or Square

- High air extraction up to 270m³/hr
- Energy efficient 30 Watt ball bearing motor
- Rated voltage 220-240V~50Hz
- Cutout size Ø245mm
- Ducting Outlet Ø100mm
- Power cord included
- Slide is ducted with draft stopper
- Cutting Template Ø245mm (on inside top flap of packaging), also provided in box
- Does not come with duct or outlet grille
- Quick and easy installation
- Ideal for bathrooms, toilets, or kitchens

SAFETY WARNING: All power outlets or electrical wiring must be installed by a licensed and qualified electrician.

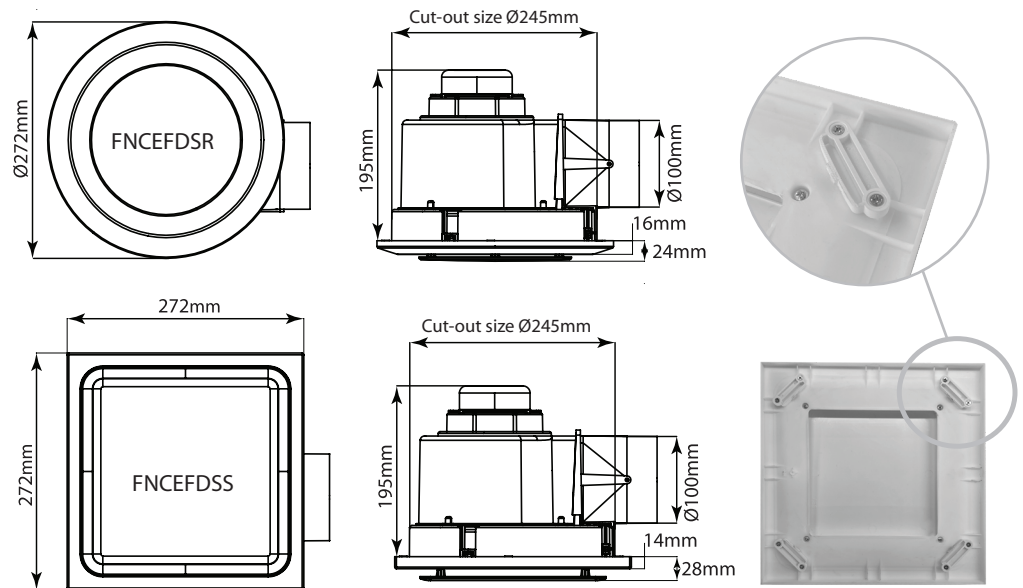

Catalogue Number	Description
FNCEFDSR	Ceiling Exhaust Fan Ducted, 245mm cut-out, Small, Round Fascia
FNCEFDSS	Ceiling Exhaust Fan Ducted, 245mm cut-out, Small, Square Fascia

Certification Number:
GMA-512149-EA

GSM Electrical (Australia) Pty Ltd
Level 2, 142-144 Fullarton Road, Rose Park SA 5067
P: 1300 301 838 F: 1300 301 778 E: service@gsme.com.au
www.gsme.com.au

