



# Power Point

## DATA SHEET

### Features

- Glass touch surface.
- Colour tuneable surfaces (RGBW).
- Slim magnetic fascia.
- Fits standard Australian wall boxes and mounting accessories that use 84mm mounting centres.
- Combination head screws with a 6mm bore to suit 4 x 2.5mm<sup>2</sup> cable (screws backed out for easier installation of cabling).
- Silverfish antenna technology.
- Bluetooth mesh connectivity with each device acting as a repeater.
- 2 year warranty.
- Real time energy use in watts & dollars.
- Automatic schedules inbuilt.
- Auto off timer (double press to ignore).
- Power outage recovery.
- Power lock.
- Individual socket control.
- Night light on/off and auto dim.
- High energy use alert.
- Voice control with your favourite voice assistant (*requires Internet and Zimi Cloud Connect*)\*

**Plus more features with the latest software version.**  
Visit [www.zimi.life](http://www.zimi.life)

### Specifications

Product Code	Colour	Description	Max Load Rating	Line Voltage Freq.
SENPP	White	Senoa Power Point Switched 2 Gang	10A @ 250V~ 2500W	50Hz Nominal
SENPPBK	Black			

### Dimensions

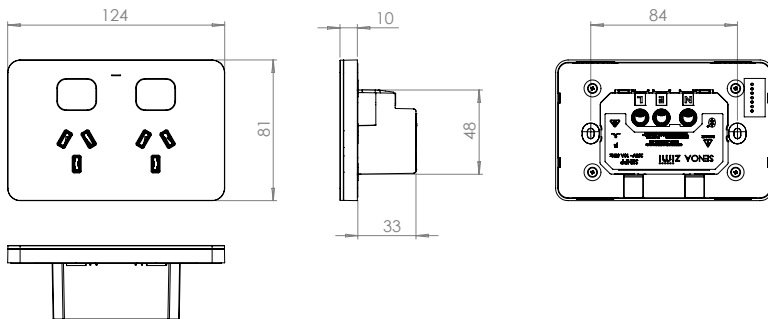

Dimensions in mm

#### Cleaning Guidelines

Ensure that switches are turned off before cleaning. Only clean the surfaces with a damp or dry cloth.

#### DO NOT

- x spray anything directly on to electrical switches or power point sockets
- x use cleaning sprays or harsh chemical cleaners
- x use an abrasive cloth
- x wash the cover plates in hot water.

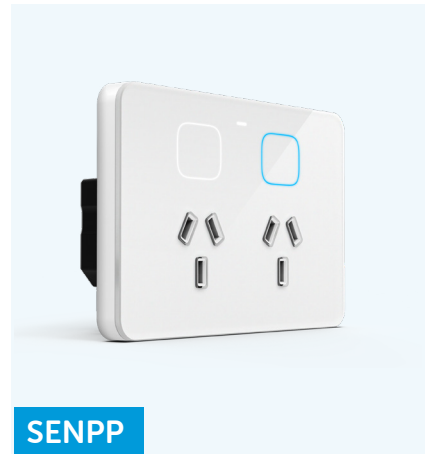

SENPPBK

**Standards Approval:**  
AS/NZS 3112 & AS/NZS CISPR15

**Certification Number:**  
GMA-511359-EA



**Download Zimi**  
Scan the code with your phone camera to download.



#### \* Zimi Cloud Connect

Control all your Zimi devices anywhere in the world via your Wi-Fi Internet.





# Multi Dimmer Switch

## 2 Button

DATA SHEET

### Features

- Glass touch surface.
  - Proximity sense illumination.
  - Colour tuneable surfaces (RGBW).
  - Slim magnetic fascia.
  - Laser engraving option for icon buttons.
  - Ripple Smooth™ technology.
  - Fits standard Australian wall boxes and mounting accessories that use 84mm mounting centres.
  - Switch terminals have 4mm bore to suit 1.5mm<sup>2</sup> cable.
  - Trailing edge dimmer.
  - Bluetooth mesh connectivity with each device acting as a repeater.
  - Silverfish antenna technology.
  - 2 year warranty.
  - Lighting and dimming control.  
Press for on/off  
Hold for dimming  
Double press for full brightness  
Triple press for a timed fade to off.
  - Auto off timer.
  - Real time energy use in watts & dollars.
  - Automatic schedules inbuilt.
  - Power outage recovery.
  - Night light on/off and auto dim.
  - Multi way switching of Senoa and other Zimi devices using Behaviour Link.
  - Min and max dimming levels for increased dimming compatibility without flicker.
  - Voice control with your favourite voice assistant. *(requires Internet and Zimi Cloud Connect)\**
- Plus more features with the latest software version. Visit [www.zimi.life](http://www.zimi.life).**

### Specifications

Product Code	Colour	Description	Rating
SENMDS2	White	Senoa Multi Dimmer Switch 2 Button	230V~ 50Hz
SENMDS2BK	Black		

Load Type per channel	Symbol	Dimmer rated load	Switch rated load
LED drivers & lamps		250W	230W
Incandescent		100W	5A
Fluorescent		×	2AX
Electronic transformers		×	2A
Standard iron core & toroidal transformers		×	2A
Small motors		×	M.20

### Dimensions

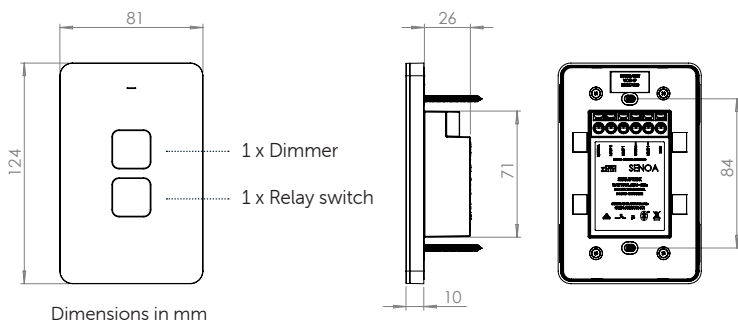

**Cleaning Guidelines**  
Ensure that switches are turned off before cleaning. Only clean the surfaces with a damp or dry cloth.

**DO NOT**  
 x spray anything directly on to electrical switches or power point sockets  
 x use cleaning sprays or harsh chemical cleaners  
 x use an abrasive cloth  
 x wash the cover plates in hot water.



**Standards Approval:**  
AS/NZ60669.2.1 & AS/NZS CISPR15

**Certification Number:**  
GMA-511367-EA



**Download Zimi**  
Scan the code with your phone camera to download.



### \* Zimi Cloud Connect

Control all your Zimi devices anywhere in the world via your Wi-Fi Internet.



**zimi** 14 Millennium Circuit, Helensvale, QLD 4212 Australia. [www.zimi.life](http://www.zimi.life)

Need help?  
<https://support.zimi.life>

SENOA products must be installed by a qualified electrician. Zimi requires a compatible (Android, iOS) mobile device, minimum OS requirements are available at [www.zimi.life](http://www.zimi.life). Availability and performance of certain features are service, device and network-dependent and may not be available in all areas; subscription(s) may be required, and additional terms, conditions and/or charges may apply. All features, functionality and other product specifications are subject to change without notice or obligation. SENOA products are optimised for the use with the Zimi App. The Bluetooth word mark and logos are registered trademarks owned by the Bluetooth SIG, Inc. IOS is a trademark or registered trademark of Cisco Inc. Zimi and Powermesh and their respective logos are registered trademarks of Zimi Ltd. Google and Google Play are trademarks of Google LLC. Amazon, Alexa, and all related logos are trademarks of Amazon.com, Inc. or its affiliates. Apple, the Apple logo, Apple Watch and iPhone are trademarks of Apple Inc., registered in the U.S. and other countries. App Store is a service mark of Apple Inc., registered in the U.S. and other countries. Copyright © 2021 Zimi Ltd. All rights reserved.



# Multi Dimmer Switch

## 4 Button

DATA SHEET

### Features

- Glass touch surface.
- Proximity sense illumination.
- Colour tuneable surfaces (RGBW).
- Slim magnetic fascia.
- Laser engraving option for icon buttons.
- Ripple Smooth™ technology.
- Fits standard Australian wall boxes and mounting accessories that use 84mm mounting centres.
- Switch terminals have 4mm bore to suit 1.5mm<sup>2</sup> cable.
- Trailing edge dimmer.
- Bluetooth mesh connectivity with each device acting as a repeater.
- Silverfish antenna technology.
- 2 year warranty.
- Lighting and dimming control.  
Press for on/off  
Hold for dimming  
Double press for full brightness  
Triple press for a timed fade to off.
- Auto off timer.
- Real time energy use in watts & dollars.
- Automatic schedules inbuilt.
- Power outage recovery.
- Night light on/off and auto dim.
- Multi way switching of Senoa and other Zimi devices using Behaviour Link.
- Min and max dimming levels for increased dimming compatibility without flicker.
- Voice control with your favourite voice assistant. *(requires Internet and Zimi Cloud Connect)\**

**Plus more features with the latest software version. Visit [www.zimi.life](http://www.zimi.life).**

### Specifications

Product Code	Colour	Description	Rating
SENMDS4	White	Senoa Multi Dimmer Switch 4 Button	230V~ 50Hz' Max 10A Total
SENMDS4BK	Black		

Load Type per channel	Symbol	Dimmer rated load	Switch rated load
LED drivers & lamps		250W	230W
Incandescent		100W	5A
Fluorescent		×	2AX
Electronic transformers		×	2A
Standard iron core & toroidal transformers		×	2A
Small motors		×	M.20

### Dimensions

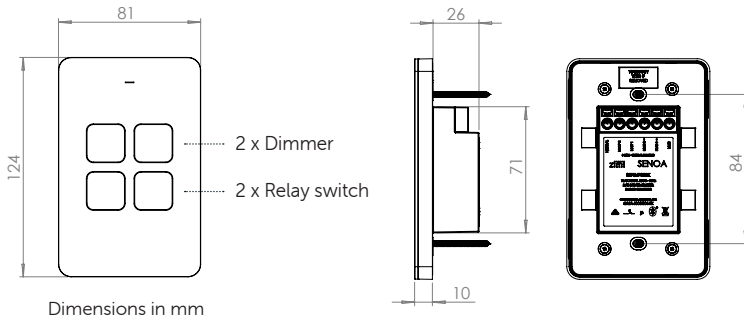

**Cleaning Guidelines**  
Ensure that switches are turned off before cleaning. Only clean the surfaces with a damp or dry cloth.

**DO NOT**  
x spray anything directly on to electrical switches or power point sockets  
x use cleaning sprays or harsh chemical cleaners  
x use an abrasive cloth  
x wash the cover plates in hot water.



SENMDS4



SENMDS4BK

**Standards Approval:**  
AS/NZ60669.2.1 & AS/NZS CISPR15

**Certification Number:**  
GMA-511367-EA



**Download Zimi**  
Scan the code with your phone camera to download.



### \* Zimi Cloud Connect

Control all your Zimi devices anywhere in the world via your Wi-Fi Internet.



**zimi** 14 Millennium Circuit, Helensvale, QLD 4212 Australia. [www.zimi.life](http://www.zimi.life)

Need help?  
<https://support.zimi.life>

SENOA products must be installed by a qualified electrician. Zimi requires a compatible (Android, iOS) mobile device, minimum OS requirements are available at [www.zimi.life](http://www.zimi.life). Availability and performance of certain features are service, device and network-dependent and may not be available in all areas; subscription(s) may be required, and additional terms, conditions and/or charges may apply. All features, functionality and other product specifications are subject to change without notice or obligation. SENOA products are optimised for the use with the Zimi App. The Bluetooth word mark and logos are registered trademarks owned by the Bluetooth SIG, Inc. IOS is a trademark or registered trademark of Cisco Inc. Zimi and Powermesh and their respective logos are registered trademarks of Zimi Ltd. Google and Google Play are trademarks of Google LLC. Amazon, Alexa, and all related logos are trademarks of Amazon.com, Inc. or its affiliates. Apple, the Apple logo, Apple Watch and iPhone are trademarks of Apple Inc., registered in the U.S. and other countries. App Store is a service mark of Apple Inc., registered in the U.S. and other countries. Copyright © 2021 Zimi Ltd. All rights reserved.



# Multi Dimmer Switch

## 6 Button

DATA SHEET

### Features

- Glass touch surface.
- Proximity sense illumination.
- Colour tuneable surfaces (RGBW).
- Slim magnetic fascia.
- Laser engraving option for icon buttons.
- Ripple Smooth™ technology.
- Fits standard Australian wall boxes and mounting accessories that use 84mm mounting centres.
- Switch terminals have 4mm bore to suit 1.5mm<sup>2</sup> cable.
- Trailing edge dimmer.
- Bluetooth mesh connectivity with each device acting as a repeater.
- Silverfish antenna technology.
- 2 year warranty.
- Lighting and dimming control.  
Press for on/off  
Hold for dimming  
Double press for full brightness  
Triple press for a timed fade to off.
- Auto off timer.
- Real time energy use in watts & dollars.
- Automatic schedules inbuilt.
- Power outage recovery.
- Night light on/off and auto dim.
- Multi way switching of Senoa and other Zimi devices using Behaviour Link.
- Min and max dimming levels for increased dimming compatibility without flicker.
- Voice control with your favourite voice assistant. *(requires Internet and Zimi Cloud Connect)\**

**Plus more features with the latest software version. Visit [www.zimi.life](http://www.zimi.life).**

### Specifications

Product Code	Colour	Description	Rating
SENMDS6	White	Senoa Multi Dimmer Switch 6 Button	230V~ 50Hz Max 10A Total
SENMDS6BK	Black		

Load Type per channel	Symbol	Dimmer rated load	Switch rated load	Spare Buttons
LED drivers & lamps		250W	230W	Behaviour Link
Incandescent		100W	5A	
Fluorescent		×	2AX	
Electronic transformers		×	2A	
Standard iron core & toroidal transformers		×	2A	
Small motors		×	M.20	

### Dimensions

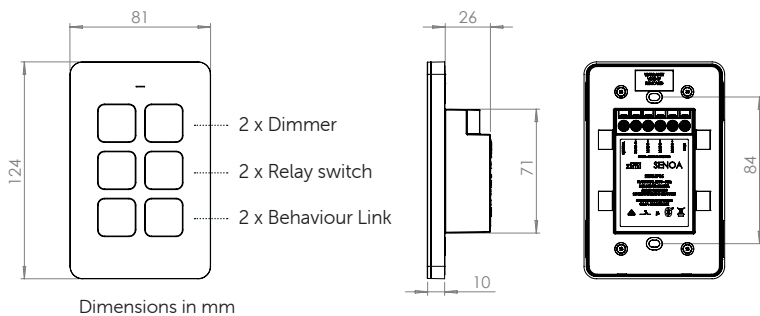

#### Cleaning Guidelines

Ensure that switches are turned off before cleaning. Only clean the surfaces with a damp or dry cloth.

#### DO NOT

- x spray anything directly on to electrical switches or power point sockets
- x use cleaning sprays or harsh chemical cleaners
- x use an abrasive cloth
- x wash the cover plates in hot water.



**Standards Approval:**  
AS/NZ60669.2.1 & AS/NZS CISPR15

**Certification Number:**  
GMA-511367-EA



#### Download Zimi

Scan the code with your phone camera to download.



#### \* Zimi Cloud Connect

Control all your Zimi devices anywhere in the world via your Wi-Fi Internet.



**zimi** 14 Millennium Circuit, Helensvale, QLD 4212 Australia. [www.zimi.life](http://www.zimi.life)

Need help?  
<https://support.zimi.life>

SENOA products must be installed by a qualified electrician. Zimi requires a compatible (Android, iOS) mobile device, minimum OS requirements are available at [www.zimi.life](http://www.zimi.life). Availability and performance of certain features are service, device and network-dependent and may not be available in all areas; subscription(s) may be required, and additional terms, conditions and/or charges may apply. All features, functionality and other product specifications are subject to change without notice or obligation. SENOA products are optimised for the use with the Zimi App. The Bluetooth word mark and logos are registered trademarks owned by the Bluetooth SIG, Inc. IOS is a trademark or registered trademark of Cisco Inc. Zimi and Powermesh and their respective logos are registered trademarks of Zimi Ltd. Google and Google Play are trademarks of Google LLC. Amazon, Alexa, and all related logos are trademarks of Amazon.com, Inc. or its affiliates. Apple, the Apple logo, Apple Watch and iPhone are trademarks of Apple Inc., registered in the U.S. and other countries. App Store is a service mark of Apple Inc., registered in the U.S. and other countries. Copyright © 2021 Zimi Ltd. All rights reserved.



# Multi Purpose Switch

## 2 Button

DATA SHEET

### Features

- Glass touch surface.
- Proximity sense illumination.
- Colour tuneable surfaces (RGBW).
- Slim magnetic fascia.
- Laser engraving option for icon buttons.
- Fits standard Australian wall boxes and mounting accessories that use 84mm mounting centres.
- Switch terminals have 4mm bore to suit 1.5mm<sup>2</sup> cable.
- Bluetooth mesh connectivity with each device acting as a repeater.
- Silverfish antenna technology.
- 2 year warranty.
- Real time energy use in watts & dollars.
- Automatic schedules inbuilt.
- Auto off timer (double press to ignore).
- Power outage recovery.
- Night light on/off and auto dim.
- Multi way switching of Senoa and other Zimi devices using Behaviour Link.
- Voice control with your favourite voice assistant. (requires Internet and Zimi Cloud Connect) \*

**Plus more features with the latest software version. Visit [www.zimi.life](http://www.zimi.life)**

### Specifications

Product Code	Colour	Description	Rating
SENMPS2	White	Senoa Multi Purpose Switch 2 Button	230V~ 50Hz Max 10A Total
SENMPS2BK	Black		

Load Type per channel	Symbol	Switch rated load
LED drivers & lamps		230W
Incandescent		5A
Fluorescent		2AX
Electronic transformers		2A
Standard iron core & toroidal transformers		2A
Small motors		M.20

### Dimensions

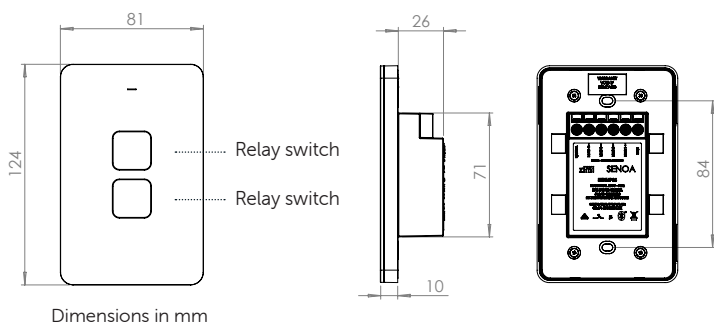

#### Cleaning Guidelines

Ensure that switches are turned off before cleaning. Only clean the surfaces with a damp or dry cloth.

#### DO NOT

- x spray anything directly on to electrical switches or power point sockets
- x use cleaning sprays or harsh chemical cleaners
- x use an abrasive cloth
- x wash the cover plates in hot water.



SENMPS2



SENMPS2BK

**Standards Approval:**  
AS/NZ60669.2.1 & AS/NZS CISPR15

**Certification Number:**  
GMA-511368-EA



#### Download Zimi

Scan the code with your phone camera to download.



#### \* Zimi Cloud Connect

Control all your Zimi devices anywhere in the world via your Wi-Fi Internet.



14 Millennium Circuit, Helensvale, QLD 4212 Australia. [www.zimi.life](http://www.zimi.life)

Need help?  
<https://support.zimi.life>

SENOA products must be installed by a qualified electrician. Zimi requires a compatible (Android, iOS) mobile device, minimum OS requirements are available at [www.zimi.life](http://www.zimi.life). Availability and performance of certain features are service, device and network-dependent and may not be available in all areas; subscription(s) may be required, and additional terms, conditions and/or charges may apply. All features, functionality and other product specifications are subject to change without notice or obligation. SENOA products are optimised for the use with the Zimi App. The Bluetooth word mark and logos are registered trademarks owned by the Bluetooth SIG, Inc. IOS is a trademark or registered trademark of Cisco Inc. Zimi and Powermesh and their respective logos are registered trademarks of Zimi Ltd. Google and Google Play are trademarks of Google LLC. Amazon, Alexa, and all related logos are trademarks of Amazon.com, Inc. or its affiliates. Apple, the Apple logo, Apple Watch and iPhone are trademarks of Apple Inc., registered in the U.S. and other countries. App Store is a service mark of Apple Inc., registered in the U.S. and other countries. Copyright © 2021 Zimi Ltd. All rights reserved.



# Multi Purpose Switch

## 4 Button

DATA SHEET

### Features

- Glass touch surface.
- Proximity sense illumination.
- Colour tuneable surfaces (RGBW).
- Slim magnetic fascia.
- Laser engraving option for icon buttons.
- Fits standard Australian wall boxes and mounting accessories that use 84mm mounting centres.
- Switch terminals have 4mm bore to suit 1.5mm<sup>2</sup> cable.
- Bluetooth mesh connectivity with each device acting as a repeater.
- Silverfish antenna technology.
- 2 year warranty.
- Real time energy use in watts & dollars.
- Automatic schedules inbuilt.
- Auto off timer (double press to ignore).
- Power outage recovery.
- Night light on/off and auto dim.
- Multi way switching of Senoa and other Zimi devices using Behaviour Link.
- Voice control with your favourite voice assistant. (requires Internet and Zimi Cloud Connect) \*

**Plus more features with the latest software version. Visit [www.zimi.life](http://www.zimi.life)**

### Specifications

Product Code	Colour	Description	Rating
SENMPS4	White	Senoa Multi Purpose Switch 4 Button	230V~ 50Hz Max 10A Total
SENMPS4BK	Black		

Load Type per channel	Symbol	Switch rated load
LED drivers & lamps		230W
Incandescent		5A
Fluorescent		2AX
Electronic transformers		2A
Standard iron core & toroidal transformers		2A
Small motors		M.20

### Dimensions

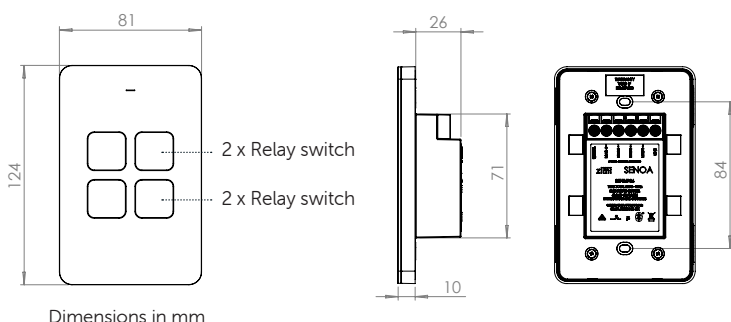

#### Cleaning Guidelines

Ensure that switches are turned off before cleaning. Only clean the surfaces with a damp or dry cloth.

#### DO NOT

- x spray anything directly on to electrical switches or power point sockets
- x use cleaning sprays or harsh chemical cleaners
- x use an abrasive cloth
- x wash the cover plates in hot water.



SENMPS4



SENMPS4BK

**Standards Approval:**  
AS/NZ60669.2.1 & AS/NZS CISPR15

**Certification Number:**  
GMA-511368-EA



#### Download Zimi

Scan the code with your phone camera to download.



#### \* Zimi Cloud Connect

Control all your Zimi devices anywhere in the world via your Wi-Fi Internet.



14 Millennium Circuit, Helensvale, QLD 4212 Australia. [www.zimi.life](http://www.zimi.life)

Need help?  
<https://support.zimi.life>

SENOA products must be installed by a qualified electrician. Zimi requires a compatible (Android, iOS) mobile device, minimum OS requirements are available at [www.zimi.life](http://www.zimi.life). Availability and performance of certain features are service, device and network-dependent and may not be available in all areas; subscription(s) may be required, and additional terms, conditions and/or charges may apply. All features, functionality and other product specifications are subject to change without notice or obligation. SENOA products are optimised for the use with the Zimi App. The Bluetooth word mark and logos are registered trademarks owned by the Bluetooth SIG, Inc. IOS is a trademark or registered trademark of Cisco Inc. Zimi and Powermesh and their respective logos are registered trademarks of Zimi Ltd. Google and Google Play are trademarks of Google LLC. Amazon, Alexa, and all related logos are trademarks of Amazon.com, Inc. or its affiliates. Apple, the Apple logo, Apple Watch and iPhone are trademarks of Apple Inc., registered in the U.S. and other countries. App Store is a service mark of Apple Inc., registered in the U.S. and other countries. Copyright © 2021 Zimi Ltd. All rights reserved.



# Multi Purpose Switch

## 6 Button

DATA SHEET

### Features

- Glass touch surface.
- Proximity sense illumination.
- Colour tuneable surfaces (RGBW).
- Slim magnetic fascia.
- Laser engraving option for icon buttons.
- Fits standard Australian wall boxes and mounting accessories that use 84mm mounting centres.
- Switch terminals have 4mm bore to suit 1.5mm<sup>2</sup> cable.
- Bluetooth mesh connectivity with each device acting as a repeater.
- Silverfish antenna technology.
- 2 year warranty.
- Real time energy use in watts & dollars.
- Automatic schedules inbuilt.
- Auto off timer (double press to ignore).
- Power outage recovery.
- Night light on/off and auto dim.
- Multi way switching of Senoa and other Zimi devices using Behaviour Link.
- Voice control with your favourite voice assistant. (requires Internet and Zimi Cloud Connect) \*

**Plus more features with the latest software version. Visit [www.zimi.life](http://www.zimi.life)**

### Specifications

Product Code	Colour	Description	Rating
SENMPS6	White	Senoa Multi Purpose Switch 6 Button	230V~ 50Hz Max 10A Total
SENMPS6BK	Black		

Load Type per channel	Symbol	Switch rated load	Spare Buttons
LED drivers & lamps		230W	Behaviour Link
Incandescent		5A	
Fluorescent		2AX	
Electronic transformers		2A	
Standard iron core & toroidal transformers		2A	
Small motors		M.20	

### Dimensions

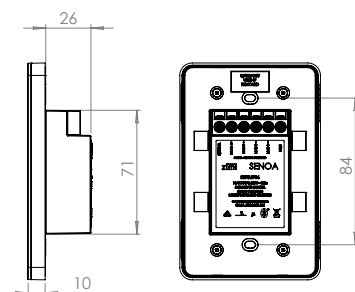
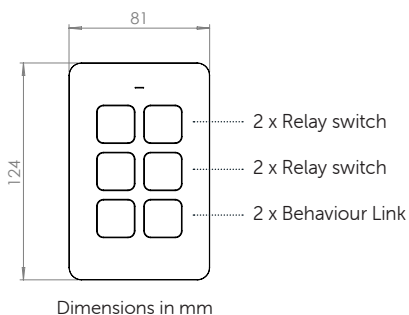

#### Cleaning Guidelines

Ensure that switches are turned off before cleaning. Only clean the surfaces with a damp or dry cloth.

#### DO NOT

- x spray anything directly on to electrical switches or power point sockets
- x use cleaning sprays or harsh chemical cleaners
- x use an abrasive cloth
- x wash the cover plates in hot water.



SENMPS6



SENMPS6BK

**Standards Approval:**  
AS/NZ60669.2.1 & AS/NZS CISPR15

**Certification Number:**  
GMA-511368-EA



#### Download Zimi

Scan the code with your phone camera to download.



#### \* Zimi Cloud Connect

Control all your Zimi devices anywhere in the world via your Wi-Fi Internet.



14 Millennium Circuit, Helensvale, QLD 4212 Australia. [www.zimi.life](http://www.zimi.life)

Need help?  
<https://support.zimi.life>

SENOA products must be installed by a qualified electrician. Zimi requires a compatible (Android, iOS) mobile device, minimum OS requirements are available at [www.zimi.life](http://www.zimi.life). Availability and performance of certain features are service, device and network-dependent and may not be available in all areas; subscription(s) may be required, and additional terms, conditions and/or charges may apply. All features, functionality and other product specifications are subject to change without notice or obligation. SENOA products are optimised for the use with the Zimi App. The Bluetooth word mark and logos are registered trademarks owned by the Bluetooth SIG, Inc. IOS is a trademark or registered trademark of Cisco Inc. Zimi and Powermesh and their respective logos are registered trademarks of Zimi Ltd. Google and Google Play are trademarks of Google LLC. Amazon, Alexa, and all related logos are trademarks of Amazon.com, Inc. or its affiliates. Apple, the Apple logo, Apple Watch and iPhone are trademarks of Apple Inc., registered in the U.S. and other countries. App Store is a service mark of Apple Inc., registered in the U.S. and other countries. Copyright © 2021 Zimi Ltd. All rights reserved.

## Features

- Suits most AC blinds with separate active wires for open/close (refer compatibility list).
- Glass touch surface.
- Open and close button (touch to stop).
- Proximity sense illumination.
- Colour tuneable surfaces (RGBW).
- Slim magnetic fascia.
- Laser engraving option for icon buttons.
- Fits standard Australian wall boxes and mounting accessories that use 84mm mounting centres.
- Switch terminals have 4mm bore to suit 1.5mm<sup>2</sup> cable.
- 2 year warranty.
- Bluetooth mesh connectivity with each device acting as a repeater.
- Silverfish antenna technology.
- Automatic schedules inbuilt.
- Night light on/off and auto dim.
- Voice control with your favourite voice assistant. (requires Internet and Zimi Cloud Connect) \*

**Plus more features with the latest software version. Visit [www.zimi.life](http://www.zimi.life)**

## Specifications

Product Code	Colour	Description	Rating
SENBC2	White	Senoa Single Blind Controller	230V~ 50Hz
SENBC2BK	Black		

Load Type per channel	Symbol	Blind 1
Small Motors M.20	(M)	300W

## Dimensions

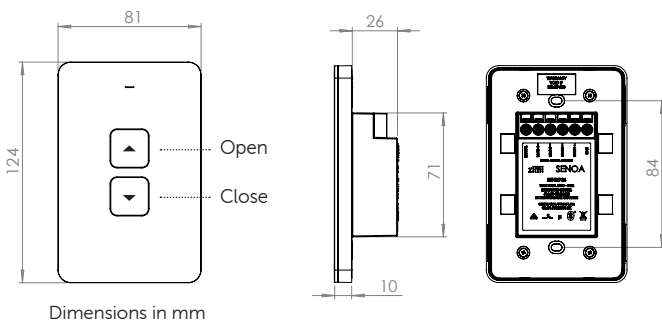

### Cleaning Guidelines

Ensure that switches are turned off before cleaning. Only clean the surfaces with a damp or dry cloth.

### DO NOT

- x spray anything directly on to electrical switches or power point sockets
- x use cleaning sprays or harsh chemical cleaners
- x use an abrasive cloth
- x wash the cover plates in hot water.



SENBC2



SENBC2BK

### Standards Approval:

AS/NZ60669.2.1 & AS/NZS CISPR15

### Certification Number:

GMA-511368-EA



### Download Zimi

Scan the code with your phone camera to download.



### \* Zimi Cloud Connect

Control all your Zimi devices anywhere in the world via your Wi-Fi Internet.





### Features

- Suits most AC blinds with separate active wires for open/close (refer compatibility list).
- Glass touch surface.
- Open and close button (touch to stop).
- Proximity sense illumination.
- Colour tuneable surfaces (RGBW).
- Slim magnetic fascia.
- Laser engraving option for icon buttons.
- Fits standard Australian wall boxes and mounting accessories that use 84mm mounting centres.
- Switch terminals have 4mm bore to suit 1.5mm<sup>2</sup> cable.
- 2 year warranty.
- Bluetooth mesh connectivity with each device acting as a repeater.
- Silverfish antenna technology.
- Automatic schedules inbuilt.
- Power outage recovery.
- Night light on/off and auto dim.
- Voice control with your favourite voice assistant. (requires Internet and Zimi Cloud Connect) \*

**Plus more features with the latest software version. Visit [www.zimi.life](http://www.zimi.life)**

### Specifications

Product Code	Colour	Description	Rating
SENBC4	White	Senoa Dual Blind Controller	230V~ 50Hz
SENBC4BK	Black		

Load Type per channel	Symbol	Blind 1	Blind 2
Small Motors M.20	Ⓜ	300W	300W

### Dimensions

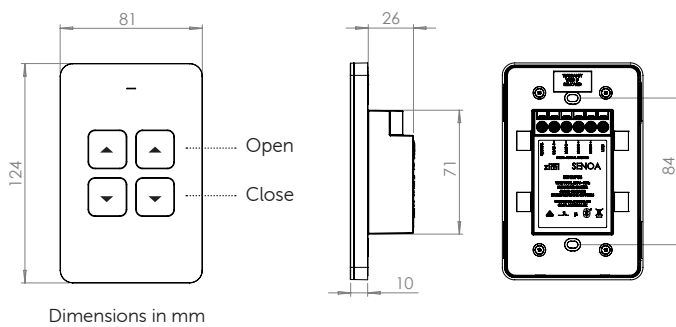

**Cleaning Guidelines**  
 Ensure that switches are turned off before cleaning. Only clean the surfaces with a damp or dry cloth.

**DO NOT**

- x spray anything directly on to electrical switches or power point sockets
- x use cleaning sprays or harsh chemical cleaners
- x use an abrasive cloth
- x wash the cover plates in hot water.



**SENBC4**



**SENBC4BK**

**Standards Approval:**  
 AS/NZ60669.2.1 & AS/NZS CISPR15

**Certification Number:**  
 GMA-511368-EA



**Download Zimi**  
 Scan the code with your phone camera to download.



### \* Zimi Cloud Connect

Control all your Zimi devices anywhere in the world via your Wi-Fi Internet.

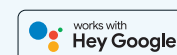



# ACCESSIBILITY RANGE Power Point

## DATA SHEET

### Features

- NDIS compliant touch pad size (>35mm wide).
- Glass touch surface.
- Colour tuneable touch pads (RGBW).
- Slim magnetic glass fascia.
- Fits standard Australian wall boxes and mounting accessories that use 84mm mounting centres.
- Bluetooth mesh connectivity with each device acting as a repeater.
- Silverfish antenna technology.
- 2 year warranty.
- Automatic schedules.
- Auto off timers.
- Real time energy usage in watts & dollars.
- Power outage recovery.
- Power lock.
- Individual socket control.
- Night light on/off and auto dim.
- High energy use alert.
- Switching from other Zimi devices with Behaviour Link.
- Voice control with your favourite voice assistant.\*

Learn more at [www.zimi.life](http://www.zimi.life)

### Specifications

Product Code	Colour	Description	Max Load Rating	Line Voltage Freq.
SNAS-PP	White	Senoa Accessibility Power Point Switched 2 Gang	10A @ 250V~ 2500W	50Hz Nominal
SNAS-PPBK	Black			

### Dimensions (mm)

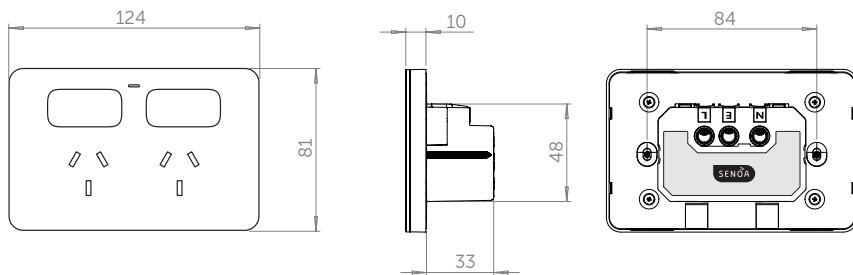

### Wiring Guide

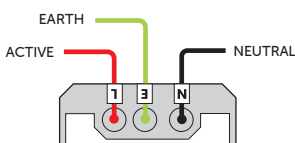

**SNAS-PP**



**SNAS-PPBK**

**Standards Approval:**  
AS/NZS 3112 & AS/NZS CISPR15

**Certification Number:**  
GMA-511359-EA



**Download Zimi**  
Scan the code with your phone camera to download.



### \* Zimi Cloud Connect

Enjoy the complete experience of all your Zimi devices with full functionality, reliable connectivity and energy history.



**zimi** 14 Millennium Circuit, Helensvale, QLD 4212 Australia. [www.zimi.life](http://www.zimi.life)

Need help? email [support@zimi.life](mailto:support@zimi.life) visit <https://support.zimi.life>

SENOA products must be installed by a qualified electrician. Zimi requires a compatible (Android, iOS) mobile device, minimum OS requirements are available at [www.zimi.life](http://www.zimi.life). Availability and performance of certain features are service, device and network-dependent and may not be available in all areas; subscription(s) may be required, and additional terms, conditions and/or charges may apply. All features, functionality and other product specifications are subject to change without notice or obligation. SENOA products are optimised for the use with the Zimi App. The Bluetooth word mark and logos are registered trademarks owned by the Bluetooth SIG, Inc. IOS is a trademark or registered trademark of Cisco Inc. Zimi and Powermesh and their respective logos are registered trademarks of Zimi Ltd. Google and Google Play are trademarks of Google LLC. Amazon, Alexa, and all related logos are trademarks of Amazon.com, Inc. or its affiliates. Apple, the Apple logo, Apple Watch and iPhone are trademarks of Apple Inc., registered in the U.S. and other countries. App Store is a service mark of Apple Inc., registered in the U.S. and other countries. Copyright © 2022 Zimi Ltd. All rights reserved.



# ACCESSIBILITY RANGE Multi Dimmer Switch

## DATA SHEET

### Features

- NDIS compliant touch pad size (>35mm wide).
- 1 x Dimmer and 2 x Switches.
- Ripple Smooth™ dimming technology.
- Trailing edge dimmer.
- Glass touch surface.
- Proximity sense touch pad illumination.
- Colour tuneable touch pads (RGBW).
- Slim magnetic glass fascia.
- Laser engraving option for icons and text.
- Fits standard Australian wall boxes and mounting accessories that use 84mm mounting centres.
- Bluetooth mesh connectivity with each device acting as a repeater.
- Silverfish antenna technology.
- 2 year warranty.
- Touch dimming control.  
Press for on/off  
Hold for dimming  
Double press for full brightness  
Triple press for a timed fade to off.
- Automatic schedules.
- Auto off timers.
- Real time energy usage in watts & dollars.
- Power outage recovery.
- Night light on/off and auto dim.
- Min and max dimming levels for increased compatibility without flicker.
- Multi way switching of other Zimi devices with Behaviour Link.
- Voice control with your favourite voice assistant.\*

Learn more at [www.zimi.life](http://www.zimi.life)

### Specifications

Product Code	Colour	Description	Rating
SNAS-MDS3	White	Senoa Accessibility Multi Dimmer Switch	230V~ 50Hz Max 10A Total
SNAS-MDS3BK	Black		

Load Type per channel	Symbol	Dimmer rated load	Switch rated load
LED drivers & lamps		250W	230W
Incandescent		100W	5A
Fluorescent		×	2AX
Electronic transformers		×	2A
Standard iron core & toroidal transformers		×	2A
Small motors		×	M.20

### Dimensions (mm)

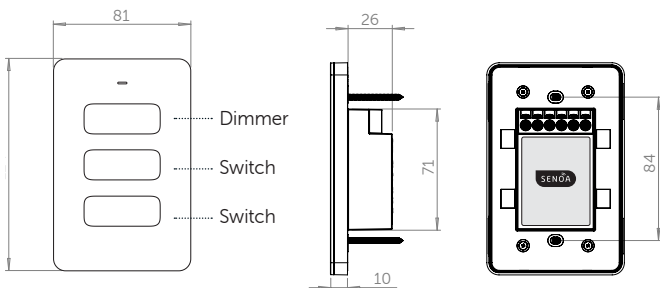

### Wiring Guide

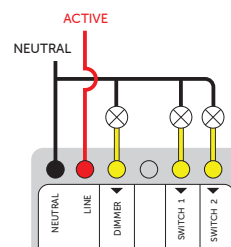

**Standards Approval:**  
AS/NZ60669.2.1 & AS/NZS CISPR15

**Certification Number:**  
GMA-511367-EA



**Download Zimi**  
Scan the code with your phone camera to download.



### \* Zimi Cloud Connect

Enjoy the complete experience of all your Zimi devices with full functionality, reliable connectivity and energy history.

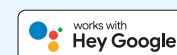

**zimi** 14 Millennium Circuit, Helensvale, QLD 4212 Australia. [www.zimi.life](http://www.zimi.life)

Need help? email [support@zimi.life](mailto:support@zimi.life)  
visit <https://support.zimi.life>

SENOA products must be installed by a qualified electrician. Zimi requires a compatible (Android, iOS) mobile device, minimum OS requirements are available at [www.zimi.life](http://www.zimi.life). Availability and performance of certain features are service, device and network-dependent and may not be available in all areas; subscription(s) may be required, and additional terms, conditions and/or charges may apply. All features, functionality and other product specifications are subject to change without notice or obligation. SENOA products are optimised for the use with the Zimi App. The Bluetooth word mark and logos are registered trademarks owned by the Bluetooth SIG, Inc. IOS is a trademark or registered trademark of Cisco Inc. Zimi and Powermesh and their respective logos are registered trademarks of Zimi Ltd. Google and Google Play are trademarks of Google LLC. Amazon, Alexa, and all related logos are trademarks of Amazon.com, Inc. or its affiliates. Apple, the Apple logo, Apple Watch and iPhone are trademarks of Apple Inc., registered in the U.S. and other countries. App Store is a service mark of Apple Inc., registered in the U.S. and other countries. Copyright © 2022 Zimi Ltd. All rights reserved.



# ACCESSIBILITY RANGE Multi Purpose Switch

## DATA SHEET

### Features

- NDIS compliant touch pad size (>35mm wide).
- Glass touch surface.
- Proximity sense touch pad illumination.
- Colour tuneable touch pads (RGBW).
- Slim magnetic glass fascia.
- Laser engraving option for icons and text.
- Fits standard Australian wall boxes and mounting accessories that use 84mm mounting centres.
- Bluetooth mesh connectivity with each device acting as a repeater.
- Silverfish antenna technology.
- 2 year warranty.
- Automatic schedules.
- Auto off timers.
- Real time energy usage in watts & dollars.
- Power outage recovery.
- Night light on/off and auto dim.
- Multi way switching of other Zimi devices with Behaviour Link.
- Voice control with your favourite voice assistant.\*

*Learn more at [www.zimi.life](http://www.zimi.life)*

### Specifications

Product Code	Colour	Description	Rating
SNAS-MPS3	White	Senoa Accessibility Multi Purpose Switch	230V~ 50Hz Max 10A Total
SNAS-MPS3BK	Black		

Load Type per channel	Symbol	Switch rated load
LED drivers & lamps		230W
Incandescent		5A
Fluorescent		2AX
Electronic transformers		2A
Standard iron core & toroidal transformers		2A
Small motors		M.20

### Dimensions (mm)

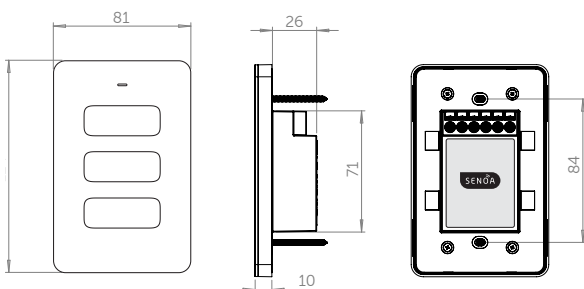

### Wiring Guide

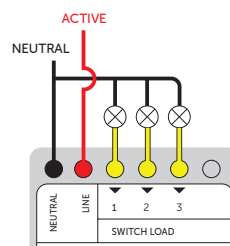

**Standards Approval:**  
AS/NZ60669.2.1 & AS/NZS CISPR15

**Certification Number:**  
GMA-511368-EA



**Download Zimi**  
Scan the code with your phone camera to download.



### \* Zimi Cloud Connect

Enjoy the complete experience of all your Zimi devices with full functionality, reliable connectivity and energy history.

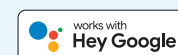

**zimi** 14 Millennium Circuit, Helensvale, QLD 4212 Australia. [www.zimi.life](http://www.zimi.life)

Need help? email [support@zimi.life](mailto:support@zimi.life) visit <https://support.zimi.life>

SENOA products must be installed by a qualified electrician. Zimi requires a compatible (Android, iOS) mobile device, minimum OS requirements are available at [www.zimi.life](http://www.zimi.life). Availability and performance of certain features are service, device and network-dependent and may not be available in all areas; subscription(s) may be required, and additional terms, conditions and/or charges may apply. All features, functionality and other product specifications are subject to change without notice or obligation. SENOA products are optimised for the use with the Zimi App. The Bluetooth word mark and logos are registered trademarks owned by the Bluetooth SIG, Inc. IOS is a trademark or registered trademark of Cisco Inc. Zimi and Powermesh and their respective logos are registered trademarks of Zimi Ltd. Google and Google Play are trademarks of Google LLC. Amazon, Alexa, and all related logos are trademarks of Amazon.com, Inc. or its affiliates. Apple, the Apple logo, Apple Watch and iPhone are trademarks of Apple Inc., registered in the U.S. and other countries. App Store is a service mark of Apple Inc., registered in the U.S. and other countries. Copyright © 2022 Zimi Ltd. All rights reserved.



# ACCESSIBILITY RANGE Blind and Light Controller

## DATA SHEET

### Features

- NDIS compliant touch pad size (>35mm wide).
- Suits most AC blinds with separate active wires for open/close (refer compatibility list).
- Open and close blinds, (touch to stop).
- On / off light switch.
- Glass touch surface.
- Proximity sense touch pad illumination.
- Colour tuneable touch pads (RGBW).
- Slim magnetic glass fascia.
- Laser engraving option for icons and text.
- Fits standard Australian wall boxes and mounting accessories that use 84mm mounting centres.
- Bluetooth mesh connectivity with each device acting as a repeater.
- Silverfish antenna technology.
- 2 year warranty.
- Automatic schedules.
- Real time energy usage in watts & dollars.
- Power outage recovery.
- Night light on/off and auto dim.
- Multi way switching of other Zimi devices with Behaviour Link.
- Voice control with your favourite voice assistant.\*

Learn more at [www.zimi.life](http://www.zimi.life)

### Specifications

Product Code	Colour	Description	Rating
SNAS-BLC	White	Senoa Accessibility Blind and Light Controller	230V~ 50Hz
SNAS-BLCBK	Black		

Load Type per channel	Symbol	Switch rated load
LED drivers & lamps		230W
Incandescent		5A
Fluorescent		2AX
Electronic transformers		2A
Standard iron core & toroidal transformers		2A

	Blind rated load
Small motors	300W

### Dimensions (mm)

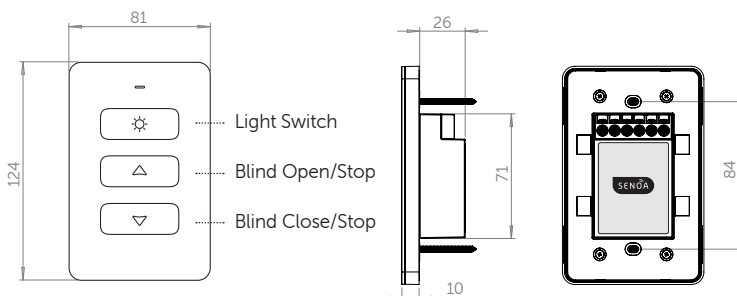

### Wiring Guide

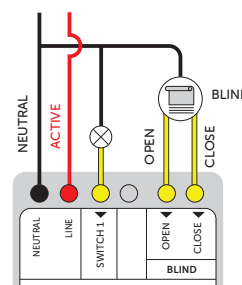

**Standards Approval:**  
AS/NZ60669.2.1 & AS/NZS CISPR15

**Certification Number:**  
GMA-511368-EA

**Bluetooth**

**Download Zimi**  
Scan the code with your phone camera to download.

GET IT ON **Google Play** | Download on the **App Store**

**\* Zimi Cloud Connect**

Enjoy the complete experience of all your Zimi devices with full functionality, reliable connectivity and energy history.

works with **Hey Google** | works with **alexa**

**zimi** 14 Millennium Circuit, Helensvale, QLD 4212 Australia. [www.zimi.life](http://www.zimi.life)

Need help? email [support@zimi.life](mailto:support@zimi.life) visit <https://support.zimi.life>

SENOA products must be installed by a qualified electrician. Zimi requires a compatible (Android, iOS) mobile device, minimum OS requirements are available at [www.zimi.life](http://www.zimi.life). Availability and performance of certain features are service, device and network-dependent and may not be available in all areas; subscription(s) may be required, and additional terms, conditions and/or charges may apply. All features, functionality and other product specifications are subject to change without notice or obligation. SENOA products are optimised for the use with the Zimi App. The Bluetooth word mark and logos are registered trademarks owned by the Bluetooth SIG, Inc. IOS is a trademark or registered trademark of Cisco Inc. Zimi and Powermesh and their respective logos are registered trademarks of Zimi Ltd. Google and Google Play are trademarks of Google LLC. Amazon, Alexa, and all related logos are trademarks of Amazon.com, Inc. or its affiliates. Apple, the Apple logo, Apple Watch and iPhone are trademarks of Apple Inc., registered in the U.S. and other countries. App Store is a service mark of Apple Inc., registered in the U.S. and other countries. Copyright © 2022 Zimi Ltd. All rights reserved.