

Cover Mounted Surface Switches

Weatherproof Range

The Hippo - Weatherproof Surface Switches are ready for all Australian conditions where installations are exposed to a variety of tough environments.

- **HPSSWCDP220 (Grey) & HPSSWCDP220BK (Black)** - 20A 250V~ rated modular weatherproof surface switches.
- Heavy duty double pole switch mechanism.
- The Hippo product is made from UV Stabilised Polycarbonate to avoid discolouring.
- IP66 ideal for prevention against water or harmful objects that may compromise conventional light switches. Perfect for use in exterior applications, or damp/dusty environments such as building exteriors, carports, gardens or workshops.
- Styling matches the rest of the Trader Hippo family of products.
- Back mounting boxes that contain 20mm and 25mm plain entries.
- Cover mounted switches for easier wiring and access .
- 20mm & 25mm plain entries in back box.
- Colour: Grey. Also available in Black, please check availability.
- AC23A to 20A.
- M160.
- Corner symmetrical screws for easy rotation of box to align entries.

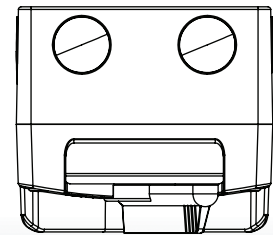
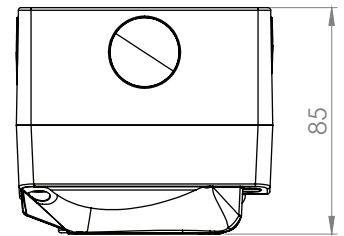
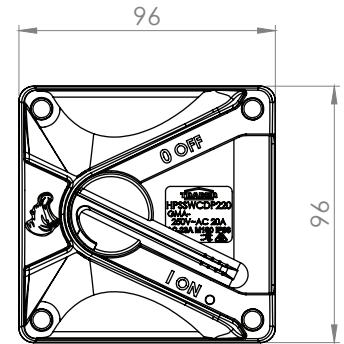

HPSSWCDP220



HPSSWCDP220BK